

SMART Centres



Simple,
Market based,
Affordable,
Repairable
Technologies

Making of Mzuzu drill



www.smartcentregroup.com



The
SMART
Centre
Group

1. Copyright and disclaimer

This manual may be copied or adapted to meet local needs, without permission from the authors, provided that there is a reference to the source (www.smartcentregroup.com).

While every care has been taken to insure the accuracy of the information in this manual, neither the publisher nor the authors can be held responsible for any damage resulting from the use of this manual. Any liability in this respect is excluded.

This manual is part 2 and is about the construction of the Mzuzu drill. For the use of the Mzuzu drill see part 1. This drilling technology is for low cost and shallow wells to be used for small scale irrigation, animal watering and / or domestic uses. If water is used for drinking, make sure that water is treated with a point of use treatment like boiling, chlorine or a good quality household water filter.

Mzuzu drilling has details which can be best learned with practical training. Therefore, it is highly recommended to use this manual in combination with practical hands-on training that can be provided by a SMART Centre in Tanzania, Malawi, Mozambique, Zambia and in the future in other countries. You can contact us at; www.smartcentregroup.com

Videos on the Mzuzu drill at;

<https://youtu.be/PxySOopYwKI>

<https://www.smartcentrezambia.com/highlights/online-training-making-a-mzuzu-drill-set-aug-2016/>

If you have observations or suggestions on this technology and or manual please contact us at info@smartcentregroup.com. We intend to update this manual every year.

Version : 1-04-2024
Authors: Henk Holtslag
Rik Haanen
Jim McGill

2. Introduction

Techniques for drilling wells can be divided into Machine drilling and Manual drilling. Machine drilled wells are called boreholes and are 30 to 100 meters deep or more and in Africa mechanical drilling rigs are imported. Manual drilled wells often are called 'Tube wells'. Manual drilling is less complex than machine drilling but takes more time and is limited to softer ground layers. Manual drilling of which the drilling tools can be produced locally include; Mzuzu drill (drills to 25 meters deep), SHIPO drill (to 50 metres deep), EMAS and Baptist drill (to 80 meters deep). These options can be produced in any African country. They can be made (after proper training) with local materials in metal shops with basic tools like a welding machine and an angle grinder. Compared to digging, the drilling of a well is less dangerous (no danger of collapsing) and can penetrate deeper into the aquifer (water bearing ground layer) so there is less risk of dry wells. Making a hygienic seal for a tube well is also easier and can be cheaper especially if the hand dug well needs a lining and is more than 10 m deep.

In aquifers with a low permeability, hand dug wells maybe more appropriate because of the large storage capacity. (Water can seep in at night and be taken out in the daytime)

The Mzuzu drill was developed by the SMART centre in Mzuzu (Malawi) and combines Augers, a Stone punch and a Tube bailer. The Tube bailer is lightweight and uses a tube (poly pipe) whereas conventional bailers are heavy and use a rope. A Mzuzu drill set cost \$100 to \$300 depending on the depth and number of drill bits. Compared to other technologies, Mzuzu drilling is simple. There is no tripod, drilling mud, sink pit or gravel pack needed so with a short training families themselves can drill a well. It can drill to 25 m deep and penetrate 2 to 6 meters into an aquifer. It can drill in sand, compacted clay and gravel and can crush stones but will not drill through very hard stone layers. This manual is part of a range of SMART Centre manuals. The complete range has manuals like:

Wells&Drilling

- Geology and site selection
- Well digging
- SHIPO drilling
- Mzuzu drilling

Pumps:

- Rope pump model 1 Standard model
- Rope pump model 2 Economy model
- Rope pump model 3 With wood poles
- Rope pump model 4 With 1 pole of Gi pipe
- Pump care-taker training
- EMAS pump
- Solar pumps

Water storage tanks

Groundwater recharge

Irrigation

Water treatment

Workshop skills

Business skills:

- Training of drilling companies.
- Business, financial and marketing planning

3. Tools and materials

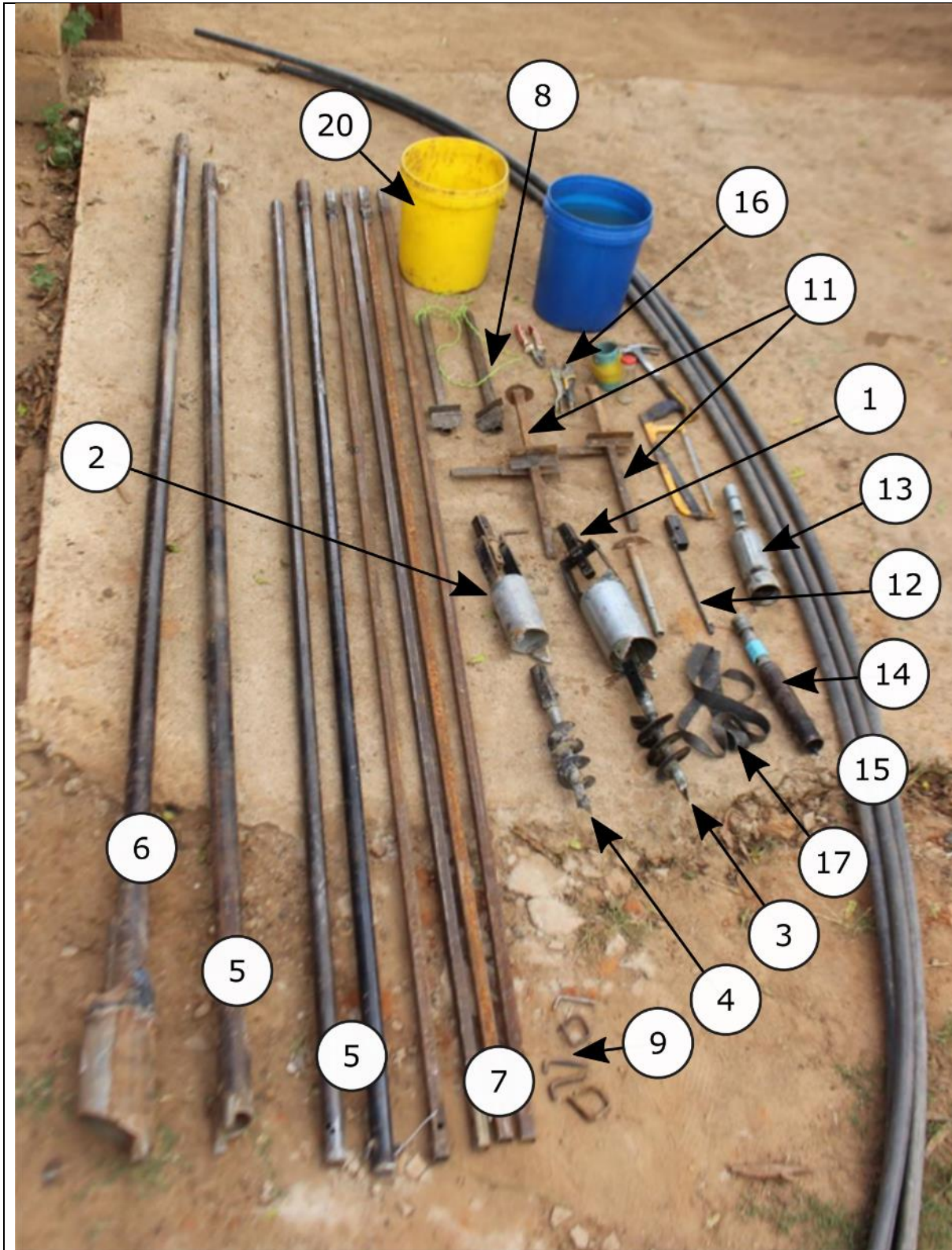

Photo 1. A Mzuzu drill set for 12 m deep wells. A table of parts is listed below.

Table of parts

No	Item	Ot.	Observations
1	Core auger 4 Inch to make holes for 4 inch casings	1	Optional: Eventually spare augers
2	Core auger 3 Inch to make holes for 2 +3 inch casings	1	3 inch can also be written as 3"
3	Spiral auger 4" to make holes for 4" casing	1	
4	Spiral auger 3" to make holes for 2" or 3" casings	1	
5	Stone punch 2" with 2 round extension pipes	1	Or use drill pipes for extension
6	Stone punch 4"		For 4" casings
7	Drill pipes Length 3 meters	6	Number depends on depth
8	Handles	2	
9	Fast fix pins	6	Number depend on depth
10	Foot step (Not in this photo)	1	See photo 5 & construction manual
11	Cleaning pins. No 1 with a pin, No 2 with a plate	2	
12	Fishing tool	1	
13	Tube bailer 3" for a 4" casing	1	
14	Tube bailer 2" for a 3" casing	1	For 2" casing, use bailer of 1.5 "
15	1" or 3/4" Poly pipe (connected to bailer) in metres	15	Or longer for deeper wells
16	Hand tools (Hacksaw, round file, knife, lighter, Vice grip (for foot step) .	1	1 each
17	Rubber strips in kg	1	Made of inner car tube
18	Clay 10 kg	1	Only needed in sandy soils
19	Spade, hoe	1	
20	Buckets of 20 litres. (strong plastic or metal)	3	
21	Drill log, Marker pens (permanent), Duct tape	2	
22	PVC pipe for casing 2" or 3" or 4" plus end cap		Number depend on depth
23	Pump to be installed, 1 bag of cement		

4. Mzuzu drill set. How to make

Material list for a drill set to 16 m deep

Material	Unit	Quant.	Observations
Square Black pipe. 25 mm. x 2mm	6 metres	3 to 5	Depending on well depth
Square Black pipe 32 mm. x 2 mm (event.1.6 mm)	6 metres	1	To connect drill pipes and augers. Pipe of 25x2 should fit inside 32x2
Round Black pipe 50 mm x 2 mm. Event 1.8mm	6 metres	1	For Stone punch
Round black pipe 32 mm Thickness 1.2 mm	6 metre	2	Eventually. For extention pipes of the Stone punch
Gi pipe ½". Thickn.1.8 mm	metres	1	For Spiral augers and Open bailer
Gi or black pipe 1" Thickn. 2.2 mm	metres	0.5	For Combi bailer
Gi or black pipe 2" Thickn. ca 2.5 mm	metres	1	For bailers , event. Stone punch
Gi or black pipe 3" Thickn. Ca2.2 mm	metres	0.2-0.4	For Core auger, eventually Bailer
Gi or black pipe 4" Thickn. ca2.5 mm	metres	0.4	For Core auger and Stone punch
Strip 40x4 mm	metres	2	For Core augers, Stone punch
Strip 25 x 3	metres	2	For drill pipes etc.
Angle iron 25x2.5	metres	2	For handles
Poly pipe, 3/4" (25mm)	metres	15	Or more depending depth. For bailer
Poly pipe, 1" (32mm)	metres	10 m	Only for wells less than 10 m deep
Sockets 1"		3 pcs	Only for closed bailers
Nipples 1"		3 pcs	Only for closed bailers
Round bar 8 mm	metres	2	For bailer valves and security pins
Round bar 6 mm	Metres	2	For bailer valves
GI wire 2 mm	Kg	1	Optional. To secure the pins
Rubber strips	Kg	1	To fix step. Or use vice grips
Tungsten drill tips	Pcs	4	For Stone punch. Or bike crank axles
Bike axles (front wheel)	Pcs	2	For bailers
Used / old files. flat or half round	Pcs	1	For Core auger and Spiral auger
Tools for the field			
Safety helmet	Pcs	2	Depending # people
Hacksaw, half round file	Pcs	1	
Pipe wrenches, 12 Inch	Pcs	2	Or similar
Buckets 20 ltrs (Metal)	Pcs	3	
Clay.	Bags 25kg	1-3	Depends diam. casing and soil type. Or Polymer, 1-5 kg
Tools for production			Vice, Angle grinder, Welder and rods, Hand drill with drills 5, 6, 10 mm. Hacksaw, Round file

Drill pipes, Pins, Handles, Footstep, Clean pins

DRILL PIPE

PIN

HANDLES

FOOTSTEP

CLEANP.

* Should fit over pipe

(13) Plate half Diameter depends on auger

Part no.	Material	Dimension	Qty.
1	Square pipe	25x25x2 - 3000	4-7
2	Square pipe	30x30x1.8-120	4-7
3	Round bar 8	ø8 - 80	1-2
4	Angle iron	25x25x2 - 70	4
5	Square pipe	25x25x2 - 300	2
6	Strip	25 x 2 - 70	4
7	Square pipe	30 x 30 - 1.8 - 70	1
8	Square pipe	25 x 25 x 2 - 120	2
9	Round bar	ø8 - 200	5-8
10	Square pipe	25x25x2 - 500	2
11	Angle iron	25x25x2 - 120	2
12	Angle iron	25x25x2 - 300	2
13	Plate	2	1/2 x 100 1



Photo 1. Mark the drill pipes with a hack saw or welding. In this way the pipes always fit



Photo 2. Fast fix pin. If too long there is danger of getting stuck

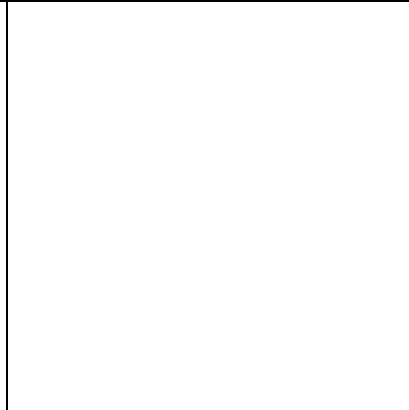

Photo 3.



Photo 4. **Handle**



Photo 5. Handle can also be made with square pipe



Photo 6. **Foot step.** Fix Foot step with a Vice grip (Photo) or a rubber strip



Photo 7. **Clean pin 1**

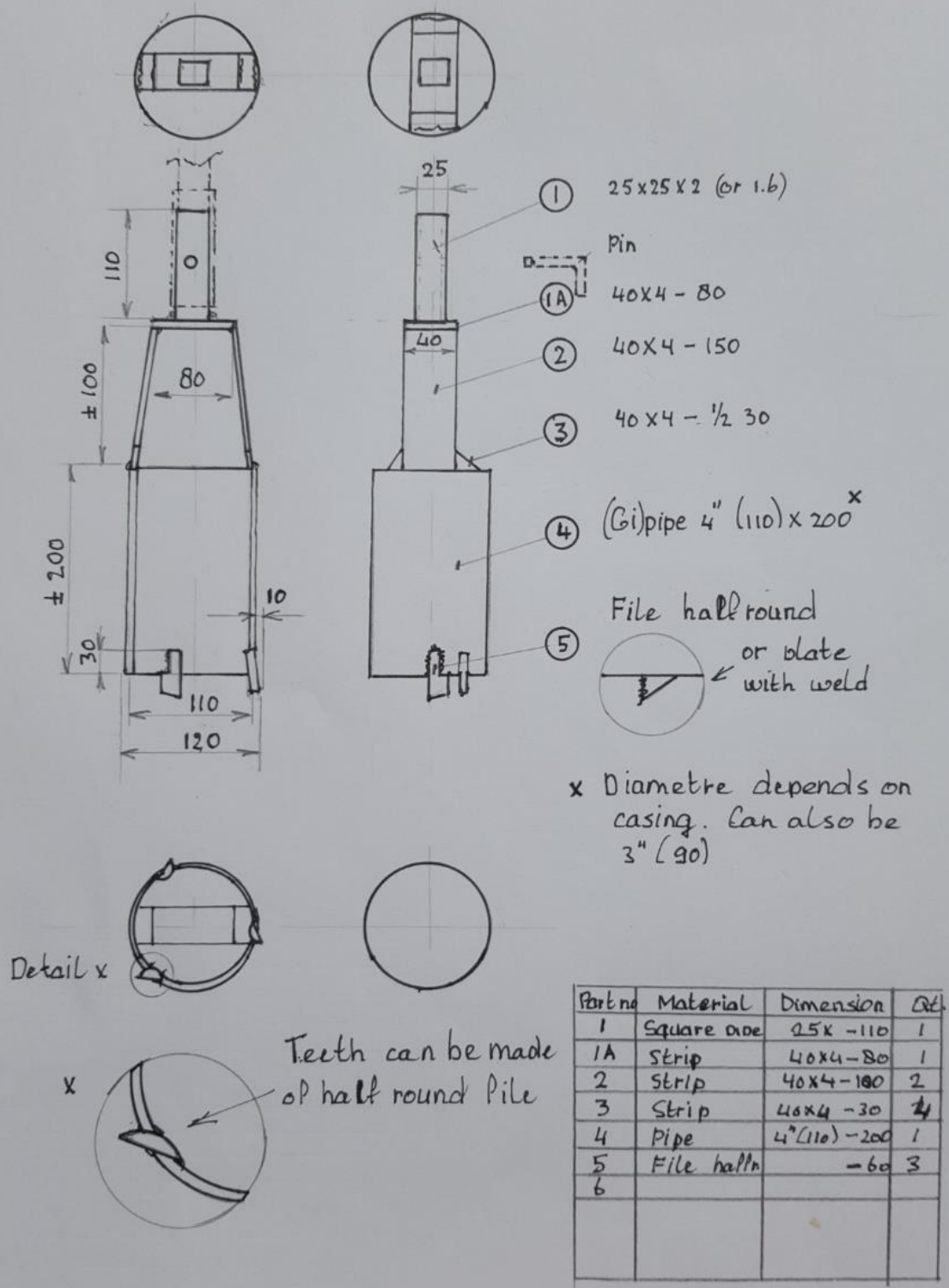

Photo 8. **Clean pin 2**



Photo 9.

CORE AUGER 4" (110)



- The diameter of a Core auger depends on the diameter of the tube well. In the drawing the auger is for a 4 inch casing (diameter 110 mm).
- Make the cutting edge hard by welding or use a flat or half round file



Photo 10. Weld the edge and grind it. Here the cutting tip is a 8 mm concrete drill with a tungsten tip



Photo 11. The cutting teeth made with a piece of a flat or half round file.



Photo 12. Note that teeth stick outside in a way that the cutting edge is outwards

Spiral Auger, Auger clean pin

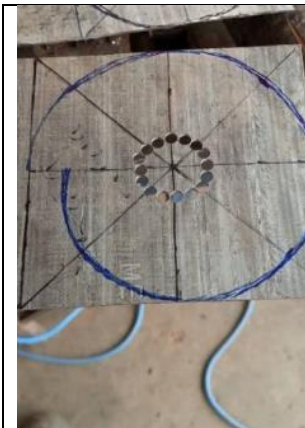

Photo 13. Hole made with 6 mm drill, and file. Hole is 7mm bigger than pipe

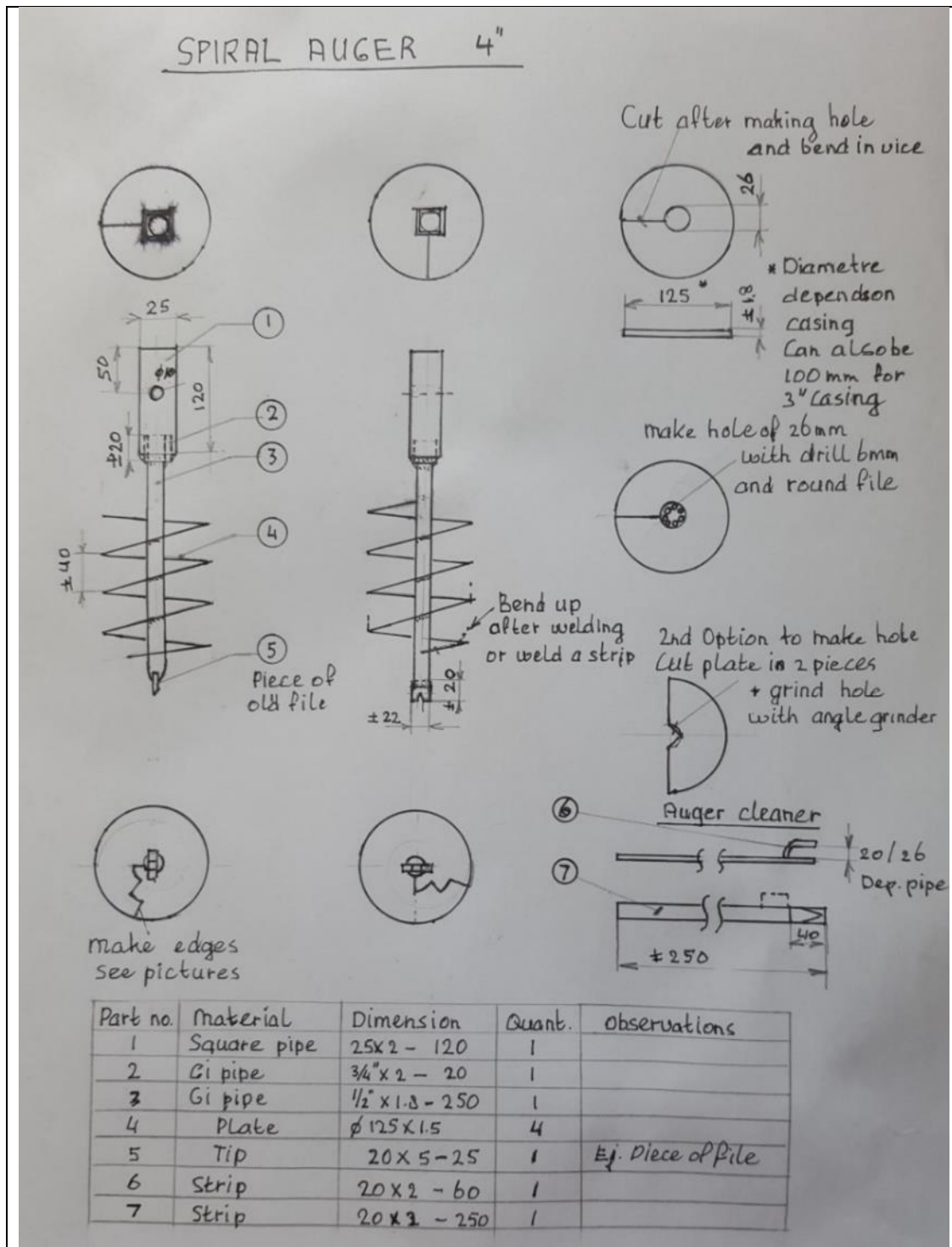

Photo 14. Bend the plate in a vice until opening is 40 mm or more.



Photo 15. You can also bend the plate by welding it on the pipe and hammer it. Here the pipe is 3/4" GI

Spiral Auger



- The Spiral auger in this drawing is for 4 inch casing (110 mm) so plates of 125 mm
- For a Spiral auger for a 3 inch casing (90mm) make plates 105 mm
- The plates can be made of a 2 inch GI pipe cut open and made flat.
- The hole in the plate should be 7 mm more than the diameter of the Centre pipe so for a 1/2" pipe (20 mm) the hole should be ca 27 mm.



Photo 16. Make cutting edge, weld a rim. (1/2" pipe)



Photo 17. Grind the cutting edge

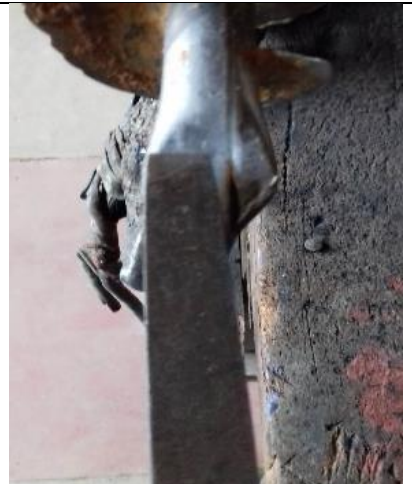

Photo 18. To make a hard tip you can use an old flat file.



Photo 19. Open the tip in the middle and grind in the right way, like this



Photo 20. Eventually you can make the tip with a stone drill of 8 mm

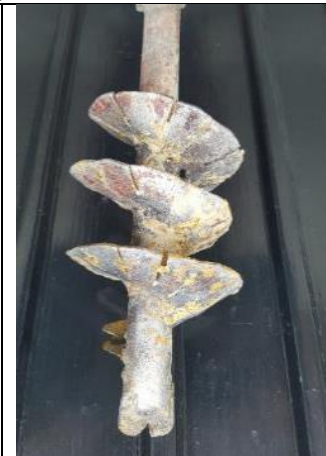

Photo 21. To increase the capacity you can bend up the plates

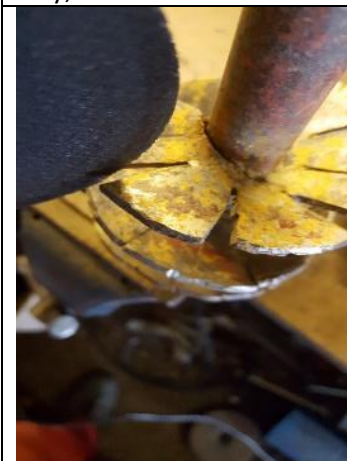

Photo 22. To bend up the plates, cut a piece, hammer the plate and spotweld



Photo 23. You can increase the lift capacity by welding a 15 mm strip around the plates



Photo 24. Spiral auger with strips

Bailers

CLOSED BAILER 2"

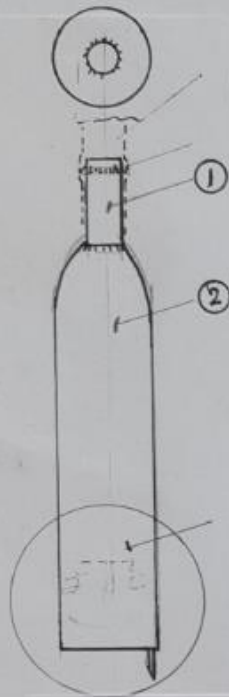

Poly pipe 1" 5-10m or more
Weld rim to avoid the poly pipe from slipping off

The same valve assembly as the COMBI BAILER

OPEN BAILER 2 inch

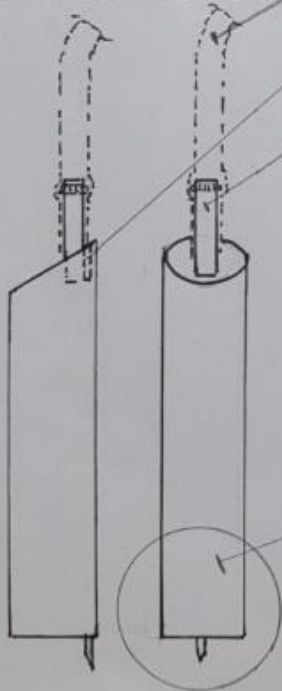

Poly pipe $\frac{3}{4}$ " or $\frac{1}{2}$ "
Height depends on well depth
Strip 20x2-40. To make some distance between $\frac{3}{4}$ " pipe and 2" pipe
GI pipe $\frac{3}{4}$ " - 100

Part no	Material	Dimension	@t.
	Poly pipe 1"	5-10m or t	1
1	GI Pipe 1"	100	1
2	GI Pipe 2"	300	1
3	Poly pipe $\frac{3}{4}$ "	10-15m or t	1
4	Strip 20x2	40	1
5	GI Pipe $\frac{3}{4}$ "	100	1

The same assembly as the COMBI BAILER

COMBI BAILER 2 INCH

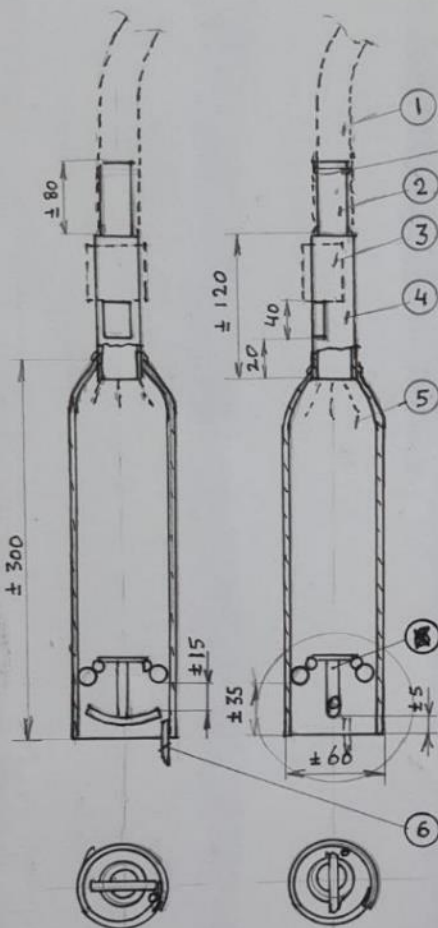

Poly pipe 1" x 5-10 m or more
Weld rim. To avoid the pipe gets loose

GI pipe 1" - 100

PVC pipe 1 1/4" Cut open

GI pipe 1 1/4" - 120 with opening

GI pipe 2" (60mm) - 300

 Cut slices + close + weld
to GI pipe 1 1/4"

Valve assembly. see detail x

Pin $\phi 6-30$

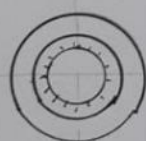

(X) Detail x

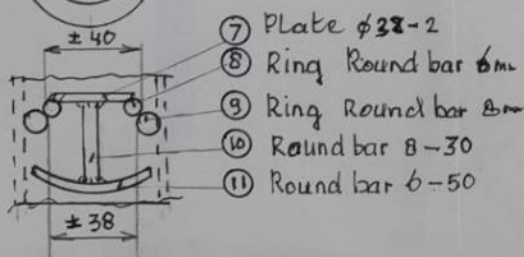

⑦ Plate $\phi 38-2$

⑧ Ring Round bar $\phi 6$ mm

⑨ Ring Round bar $\phi 8$ mm

⑩ Round bar 8-30

⑪ Round bar $\phi 6-50$

Part no	Material	Dimension	Qt
1	Poly pipe 1"	5-10 m deb.	1
2	GI pipe 1"	100 mm	1
3	PVC pipe 1 1/4"	60 mm	1
4	GI pipe 1 1/4"	120 mm	1
5	GI pipe 2"	300 mm	1
6	Round bar $\phi 6$	30 mm	1
7	Plate 2mm	$\phi 38$ mm	1
8	Round bar $\phi 6$	$\phi 40$ outside	1
9	Round bar $\phi 8$	$\phi 56$ outside	1
10	Round bar $\phi 8$	35 mm	1
11	Round bar $\phi 6$	50 mm	1

- The diameter of the bailer depends on the casing to be used
- These drawings show a 2 inch bailer to be used for 3 inch casings
- If you start drilling, start with the Simple **Open bailer**





		
<p>Photo 25. Making of a valve seat by bending round bar 8 mm around a 1.25 Inch pipe</p>	<p>Photo 26. Valve with round bar 6 mm. The outside diameter of the valve should be 2 a 3 mm more than inside valve seat</p>	<p>Photo 27. Valve assembly</p>
		
<p>Photo 28. Here valve assemble for a 3 inch bailer. Valve seat made with ring 8 mm and ring 6 mm.</p>	<p>Photo 29. Valve made with round bar 6 mm and a plate of 2 mm</p>	<p>Photo 30. Place valve assembly inside the pipe. Here it is kept straight with 2 wires welded in 2 slots made by angle grinder</p>
		
<p>Photo 31. Weld the valve seat on the bottom sides with tack welds</p>	<p>Photo 32. Weld 1 or 2 pins at the pipe bottom (ej axle of bike wheel).</p>	<p>Photo 33.</p>



Photo 34. Simple open bailer



Photo 35.

Stone punch



Photo 36. Stone punch

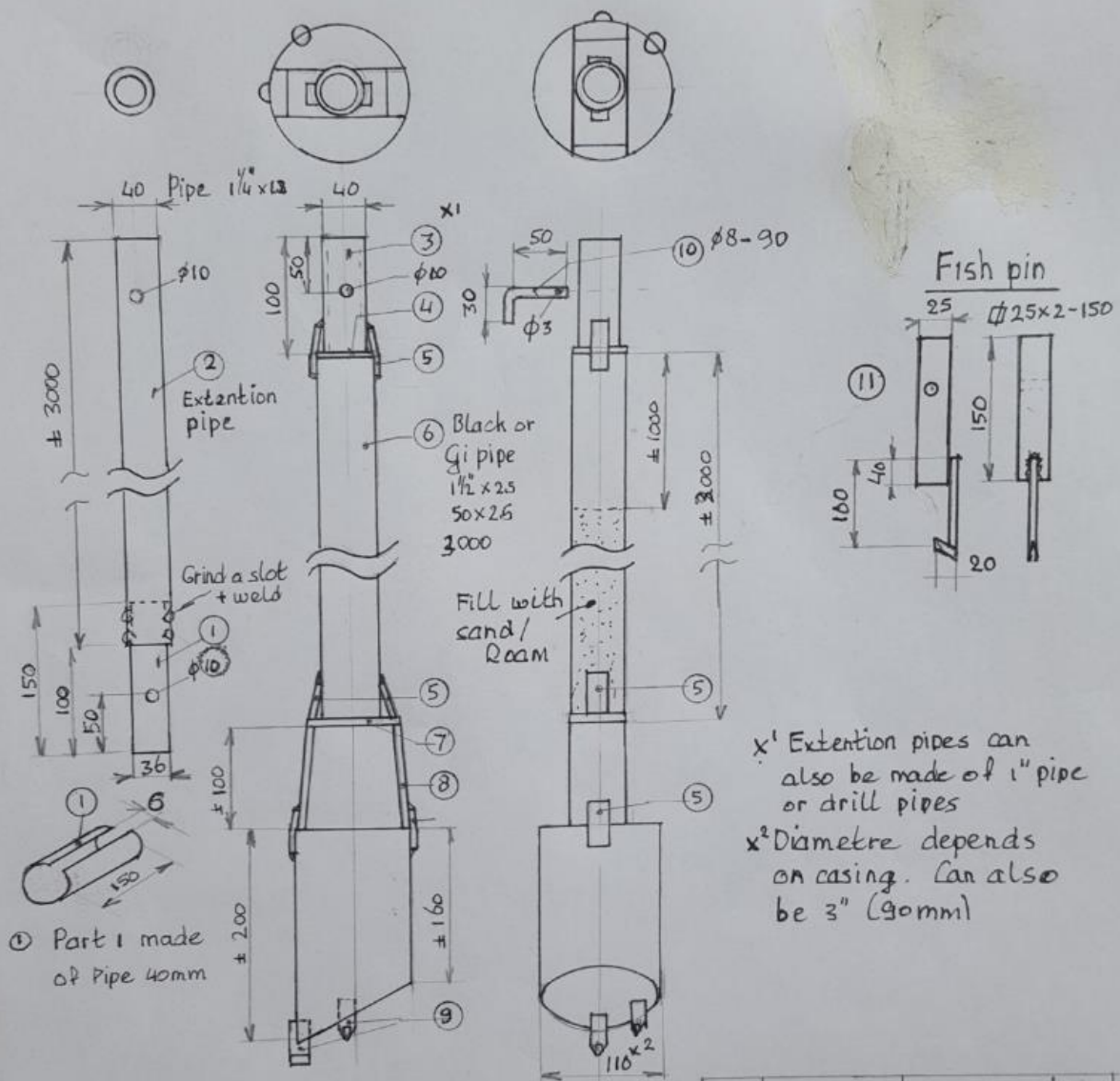

Photo 37. This model uses a tungsten tip. Note the position of the tip.



Photo 38. The punch can be cleaned with the Clean pin

STONE PUNCH 4"



x¹ Extension pipes can also be made of 1" pipe or drill pipes
 x² Diametre depends on casing. Can also be 3" (90mm)

Part no	Material	Dimension	Qt.
1	Black pipe	1 1/2" (40x1.2)-150	0-4
2	Black pipe	1 1/4" (40x1.2)-3000	0-4
3	Black pipe	1 1/4" (40x1.2)-100	1-4
4	Strip	40x4 - 40	1
5	Strip	25x2 - 50	4
6	Black pipe	1 1/2" (50x1.2)-3m	
7	Strip	40x4 - 70	1
8	Strip	40x4 - 100	2
9	Tungsten	50x20	2
10	Round bar	φ8 - 80	1-4
11	Fish pin		

- The pipe of the Stone punch needs to be of good quality preferable 3 mm thick
- If that is not available, weld a reinforcement plate at the side where the tip is